

# Model 90si

## Secure Fax Gateway

### User's Guide



GateWay  
Fax  
Systems, Inc.

Secure Fax Products  
Virginia, USA  
Tel: 804-796-1900  
Toll-Free: 877-951-9800  
Fax: 804-796-1116  
E-Mail: [info@gwfs.com](mailto:info@gwfs.com)  
Web: [www.gwfs.com](http://www.gwfs.com)  
Help Line: 877-951-9814

Revision 4.5  
12/8/2010



## Table of Contents

<b>90si Quick Reference Guide</b> . . . . .	<b>.2</b>
Connecting the COTS fax, 90si and Crypto . . . . .	.2
Transmitting a Secure Fax . . . . .	.2
Receiving a Secure Fax . . . . .	.2
<b>1.0 Getting Started</b> . . . . .	<b>.5</b>
1.1 Introduction . . . . .	.5
What's New . . . . .	.5
General Description and Benefits of the 90si . . . . .	.5
1.2 What in the Box . . . . .	.5
1.3 Looking at your 90si . . . . .	.6
<b>2.0 Installation</b> . . . . .	<b>.7</b>
2.1 Choosing a COTS Fax. . . . .	.7
2.2 Choose a Location. . . . .	.7
2.3 Choose a Configuration . . . . .	.7
2.3.1 Secure Only Configuration (Recommended) . . . . .	.8
2.3.2 Dual Mode Considerations . . . . .	.8
2.3.3 Configuration Selection Chart . . . . .	.8
2.3.4 1-Line, Dual-Mode . . . . .	.9
2.3.5 2-Line Dual-Mode . . . . .	.10
2.3.6 1-Line Dual-Mode with 910 Option . . . . .	.11
2.3.7 1-Line Dual-Mode with an A/B Switch. . . . .	.12
2.4 Setting Your Chosen Configuration . . . . .	.12
2.5 Print the Default Settings List. . . . .	.13
2.6 Setting Up Your Encryption Device. . . . .	.15
2.6.1 L-3 Secure Terminal Equipment (STE) . . . . .	.15
2.6.2 L-3 OMNI / OMNIxi . . . . .	.16
2.6.3 General Dynamics Sectera Wireline Terminal . . . . .	.17
2.6.4 General Dynamics Sectera vIPer . . . . .	.18
2.6.5 Motorola STU-IIB & STU-IIIa. . . . .	.19
<b>3.0 Using your 90si</b> . . . . .	<b>.20</b>
3.1 Applying Power . . . . .	.20
3.2 Sending a Secure Fax . . . . .	.20
3.3 Receiving a Secure Fax . . . . .	.20
3.4 Sending a Public Fax (Dual-Mode Configurations Only). . . . .	.20
3.5 Receiving a Public Fax (Dual-Mode Configurations Only). . . . .	.21
3.6 90si Status Lights . . . . .	.21
Power-Up . . . . .	.21
Communication Errors . . . . .	.21
System Errors . . . . .	.21
3.7 Selecting a Transmit Protocol . . . . .	.22
3.7.1 SCIP Async Protocol . . . . .	.22
3.7.2 MIL-STD-161 Protocols (Synchronous) . . . . .	.22
Handshake with FEC Off . . . . .	.22
Handshake with FEC On . . . . .	.22
Broadcast with FEC Off . . . . .	.22
Broadcast with FEC On . . . . .	.22
3.7.3 Full and Half Duplex . . . . .	.22

## Table of Contents (continued)

3.8	Setting and Using the Default Transmit Protocol . . . . .	.23
3.9	Using a One-Time Transmit Protocol Code . . . . .	.24
<b>4.0</b>	<b>If There's a problem . . . . .</b>	<b>.25</b>
4.1	How Will You Know . . . . .	.25
	The 90si Front Panel LED's . . . . .	.25
	Indicators On Your Fax Machine . . . . .	.25
	Find Your COTS Fax Manual Here . . . . .	.25
4.2	Troubleshooting Tips . . . . .	.25
	Fax Auto-Answer . . . . .	.25
	90si Configuration . . . . .	.25
	Secure Data Mode . . . . .	.25
	Interconnect Cables . . . . .	.25
	Make a Copy . . . . .	.25
	Place a Call of the STE or Secure Phone . . . . .	.25
	Send and Receive a Public Fax . . . . .	.26
4.3	When All Else Fails...Call Our Help Line . . . . .	.26
<b>5.0</b>	<b>Warranty Information . . . . .</b>	<b>.26</b>
<b>6.0</b>	<b>Specifications . . . . .</b>	<b>.26</b>
6.1	General Specifications . . . . .	.26
6.2	Digital Interface Specifications . . . . .	.27
<b>7.0</b>	<b>Related Web Links . . . . .</b>	<b>.28</b>
<b>8.0</b>	<b>Safety Information and FCC Requirements . . . . .</b>	<b>.28</b>
<b>9.0</b>	<b>Glossary . . . . .</b>	<b>.31</b>

## 1.0 Getting Started

### 1.1 Introduction

#### What's New

In 2010 we began shipping 90si's with a number of new features including the SCIP Interoperable Async Secure Fax Protocol or Async for short. This protocols allows the 90si to communicate with all other Async capable secure fax using STE, OMNI, Sectera and other SCIP capable cryptos in Async Secure Data Mode. We also eliminated the DIP switches (on the bottom of the old units) used for setting the transmit protocol and configuration. Now, the user sets the default configuration and protocol using the attached fax's dial pad. The last major change is the addition of a remote software/firmware upgrade mechanism.

#### General Description and Benefits of the 90si

The 90si Secure Fax Gateway allows any current or future commercial fax device to connect to a STE, OMNI, Sectera or other cryptographic device. That leaves the choice of facsimile features in your hands. You choose the fax that best suits your needs, such as: toner or ink-jet, multi-function or fax only, portable, high-volume/low-volume, computer-based fax, whatever you like !! The 90si also preserves your choices for the future by allowing you to easily and economically upgrade your fax machine as technology and requirements change or if your old fax simply wears out, as they all will. With all-in-one secure faxes, you must throw away your investment in the secure fax protocols (the 90si like electronics that they build into their faxes) along with the fax machine. Being an external device, you retain your investment in the 90si and replace only the COTS fax machine (at COTS prices) when necessary.

Thank you for your purchase of the 90si Secure Fax Gateway.

### 1.2 What in the Box

Before you install the Easy-Fax 90si STU-III Gateway, make sure that you have received the following items:



**90si Main Unit**



**AC Power Supply**



**AC Power Cord**



**Phone Cord**

Additional items required for your 90si secure fax system are:

1. A COTS fax machine or a computer with fax capability
2. An operational STE, OMNI, SECTERA, STU-IIB or other cryptographic device.
3. An outside phone line.

### 1.3 Looking at your 90si

The figures below indicate the location and functions of the 90si buttons, indicators and connectors.

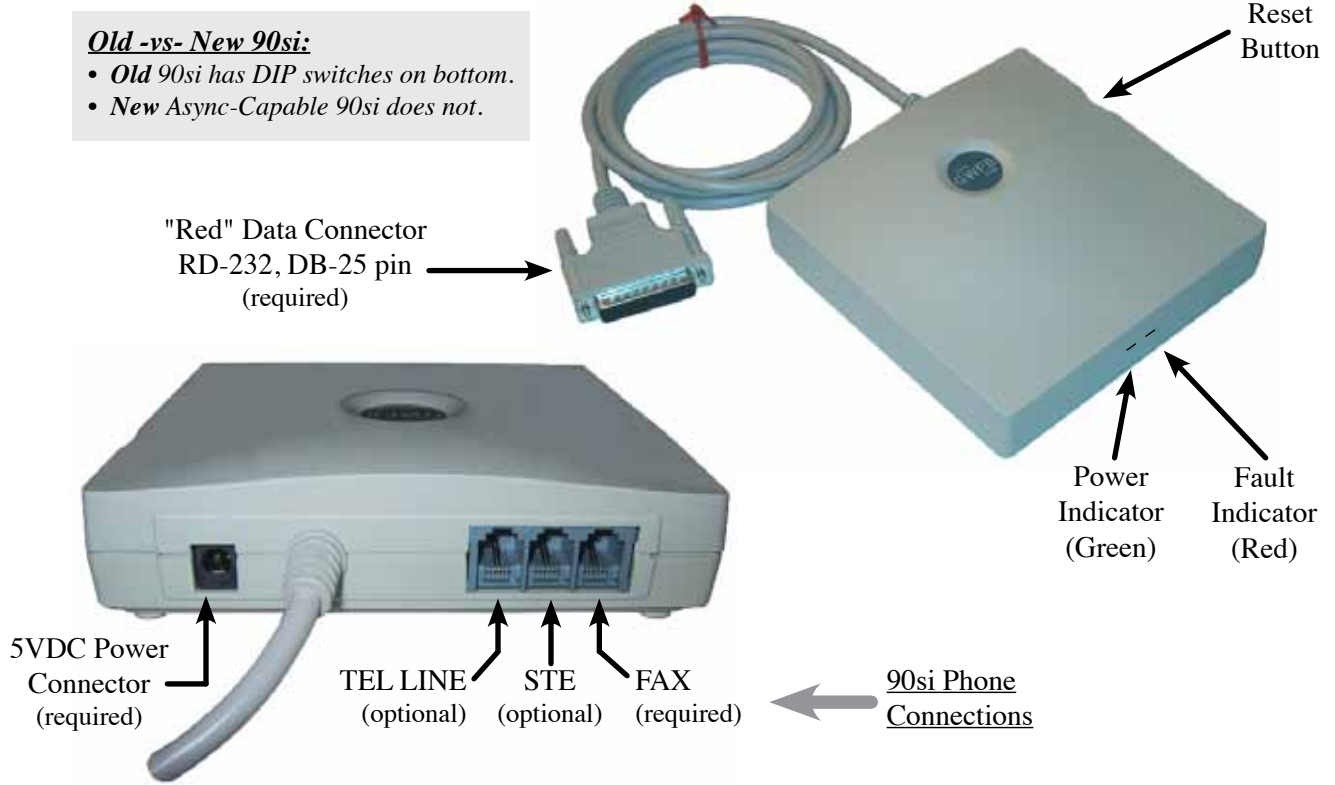

*Figure x - Looking at your 90si*

<b>RESET</b> Button	When pressed it causes a hardware and software reset. While the light is blinking, self-tests are executed. When the light is on steady, the unit is ready to operate.
<b>FAULT</b> Indicator (Red)	It illuminates for 90 seconds following an error condition and is off during normal operation.
<b>POWER</b> Indicator (Green)	When illuminated, power is applied and self-tests were successful.
<b>STE</b> "Red" Data Cable (required)	This serial data cable is terminated with an RS-232 (25 Pin) connector that goes to the "Red" Data Port on the back of your secure telephone or crypto.
<b>FAX</b> Connector (required)	This connector is used for all configurations. It connects to the "Line" or "L" jack on your COTS or computer-based fax.
<b>STE</b> Connector (optional)	Used only for the 1-Line, Dual-Mode configuration where it connects to the PSTN jack on the Secure Phone. It is not used for the Secure Only or 2-Line Dual-Mode configurations.
<b>TEL LINE</b> Connector (optional)	Used only for Dual-Mode configurations (1-Line Dual-Mode or 2-Line Dual-Mode) where it connects to a commercial 2-wire loop telephone line.
<b>EXT. 5VDC SUPPLY</b> (required)	This connects to the supplied 110-220VAC auto-sensing power supply.

## 2.0 Installation

### 2.1 Choosing a COTS Fax

By the nature of their design, Secure Telephones require operator intervention to place and receive calls and transition those call into and out of Secure Voice, Secure Data and Clear Voice modes. It is for this reason that we recommend that you choose one of the more basic COTS faxes to connect to your 90si. All of the COTS faxes automated features will not function in the Secure environment.

If possible, choose a COTS fax with a Hook, Monitor or Manual-Dial button. This Hook button takes the fax machine off-hook just as if you had lifted the handset of a phone. Whatever it may be called, using this button to send a secure fax will cause the fax machine to enter what is usually called the "manual transmission" mode whereby pages are scanned and sent one at a time. In this way you will know, at a glance from across the room, the status of the transmission and when the transmission is complete.

#### **Memory Issues:**

Additionally, static or permanent memory can be an issue when handling classified document. Gateway Fax Systems offers COTS faxes that have only dynamic memory, the contents of which is erased when the power is removed. Contact us if you wish to acquire one of these specially modified COTS faxes. And, as always, the 90si never retains any facsimile image data as it constantly overwrites image memory. Additionally, the memory chips used in the 90si are volatile. You may be doubly certain that no classified data remains in the 90si by depressing the Reset button, as image memory is also overwritten during the reset process.

### 2.2 Choose a Location

Pick a spot that is within five (5) feet of your COTS fax, secure telephone or crypto, telephone line connection(s) and an AC power outlet. We recommend that you place the COTS fax on the left and your Secure Telephone on the right with the 90si in between the two.

### 2.3 Choose a Configuration

The 90si's primary function is to allow your COTS fax to become a secure fax. The simplest (and recommended) configuration is called the **Secure Only**. If you choose, however, your 90si based secure fax system can also be used to send and receive unclassified fax messages; See Section 2.3.2 Dual Mode Considerations.

### 2.3.1 Secure Only Configuration (Recommended)

This factory default configuration allows the attached COTS fax to function only as a secure fax. If you wish to process Public or Unclassified documents as well; see Section 2.3.2 Dual-Mode Considerations.

If your 90si is factory fresh, it is already pre-set to operate in this mode. If it has been in another location or you are unsure of the current setting, **set the Configuration to (01) Secure Only**. See Section 2.4, Setting Your Chosen Configuration for instructions on how to do this.

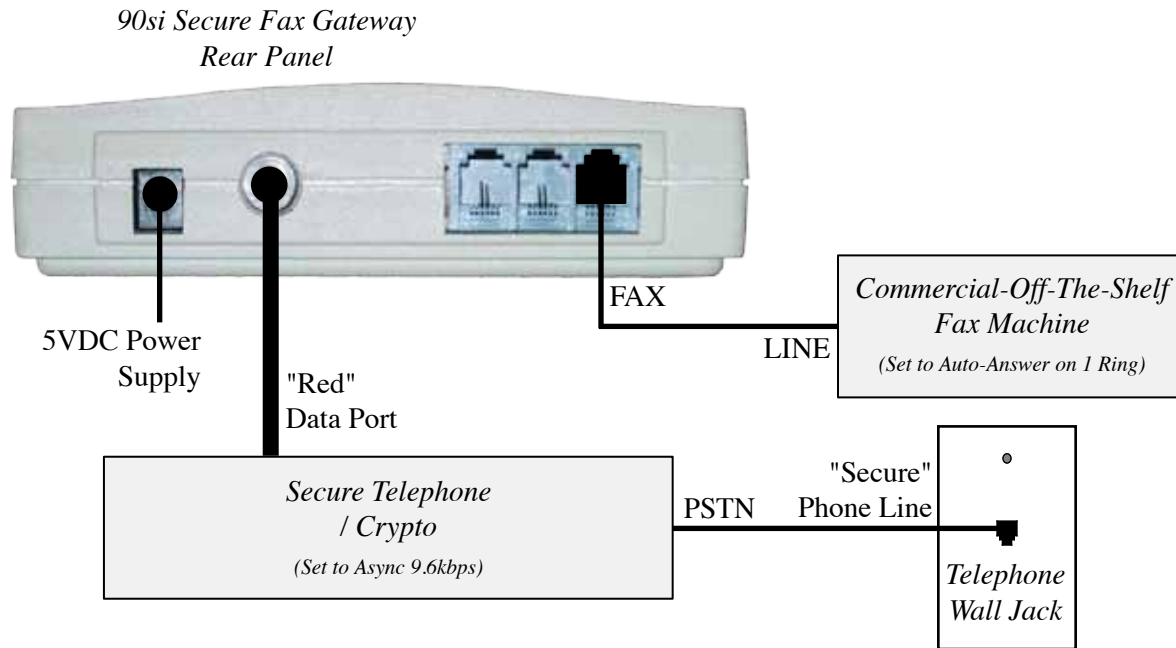

*Figure 1: Default Factory Configuration, Secure Only*

### 2.3.2 Dual Mode Considerations

We define Dual-Mode as any 90si configuration that allows the COTS fax to directly access an outside line, around the Secure Telephone, thus enabling the transmission and reception of unclassified faxes. The differentiation between sending a document using the Secure Phone's Secure Data Mode (a secure fax) and sending that same document to a non-secure fax is procedural. Therefore, if your 90si is configured for Dual-Mode, an untrained operator could compromise a document. It is for this reason that the 90si is factory set to the Secure Only mode.

If untrained (regarding the 90si) people have access to your secure fax location, use the Secure Only Configuration and have the users go elsewhere for unclassified faxes. If, on the other hand, a limited number of people have access to the 90si, and they can all be trained on safe 90si operation, then one of the Dual-Mode configurations may be appropriate for the location.

If you wish to use your 90si system for *both* secure and non-secure (unclassified) fax documents choose one of the following dual-mode configurations.

### 2.3.3 Configuration Selection Chart

The following chart will assist you in choosing the 90si configuration that best suits your requirements.

<b>Configuration</b>	<b>Secure Operation</b>	<b>Non-Secure Operation</b>	<b>Description</b>
Secure Only	Primary	n/a	For Secure Fax operation only (factory default setting); See Section 2.3.1 Secure Only Configuration.
2-Line Dual-Mode	Primary	Primary	For primary Non-Secure fax and primary Secure fax operation using 2 separate telephone lines; See Section 2.3.5.
1-Line Dual-Mode	Primary	Secondary	For secondary Non-Secure fax and primary Secure fax operation using 1 telephone line for all functions; See Section 2.3.4.
1-Line Dual-Mode with an A/B Switch	Manual Secure of Non-Sec	Manual Secure of Non-Sec	For manual, selective Secure and Non-Secure fax operation using 1 telephone line for either Non-Secure fax OR Secure operation. See Section 2.3.7.
1-Line Dual-Mode with 910 Option	Primary	Primary	For primary Non-Secure and primary Secure fax operation, automatically, using only 1 telephone line. See Section 2.3.6.

NOTE: **Primary** is defined as a secure fax that operates as you would expect, without any unique or unusual steps. For non-secure fax operation, it means that the COTS fax will automatically answer an incoming non-secure fax call, just like all of the dedicated non-secure faxes you have used. **Secondary** means that an operator will have to be present to receive a non-secure fax call.

### 2.3.4 1-Line, Dual-Mode

With this configuration your fax will function as a Secondary non-secure fax as well as your primary secure fax. Only one phone line is required, however an operator must be present to receive a non-secure fax.

**Set the Configuration to (02) 1-Line Dual-Mode.** See Section 2.4, Setting Your Chosen Configuration for instructions on how to do this.

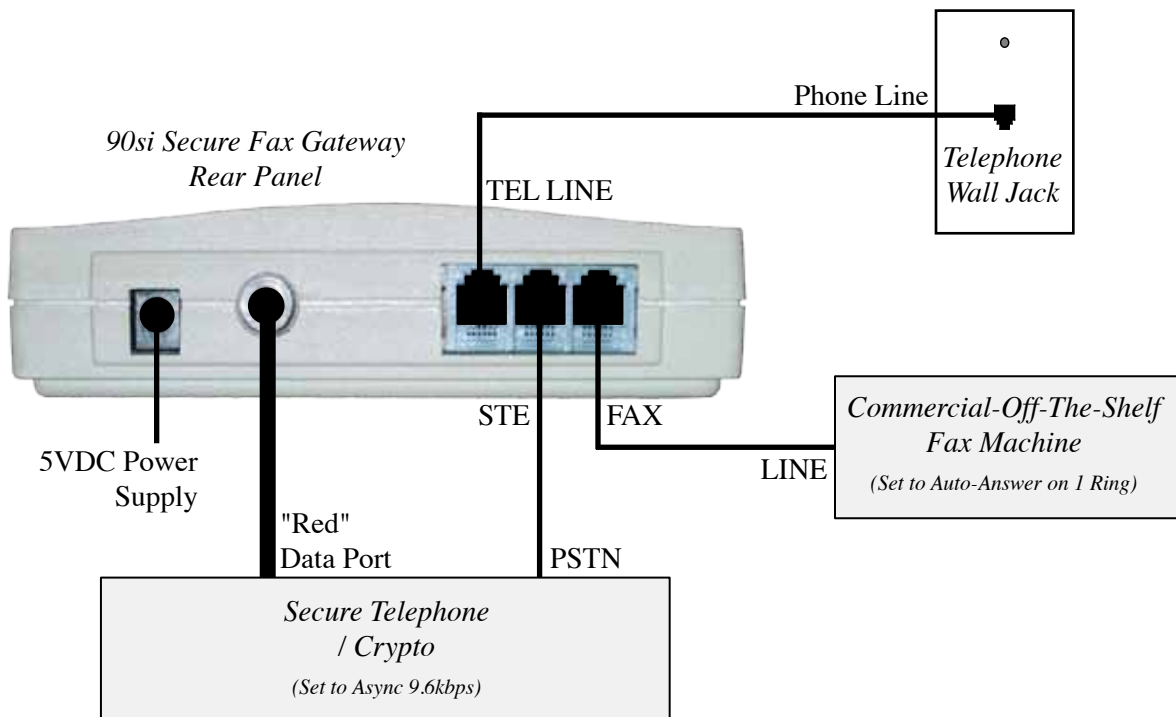
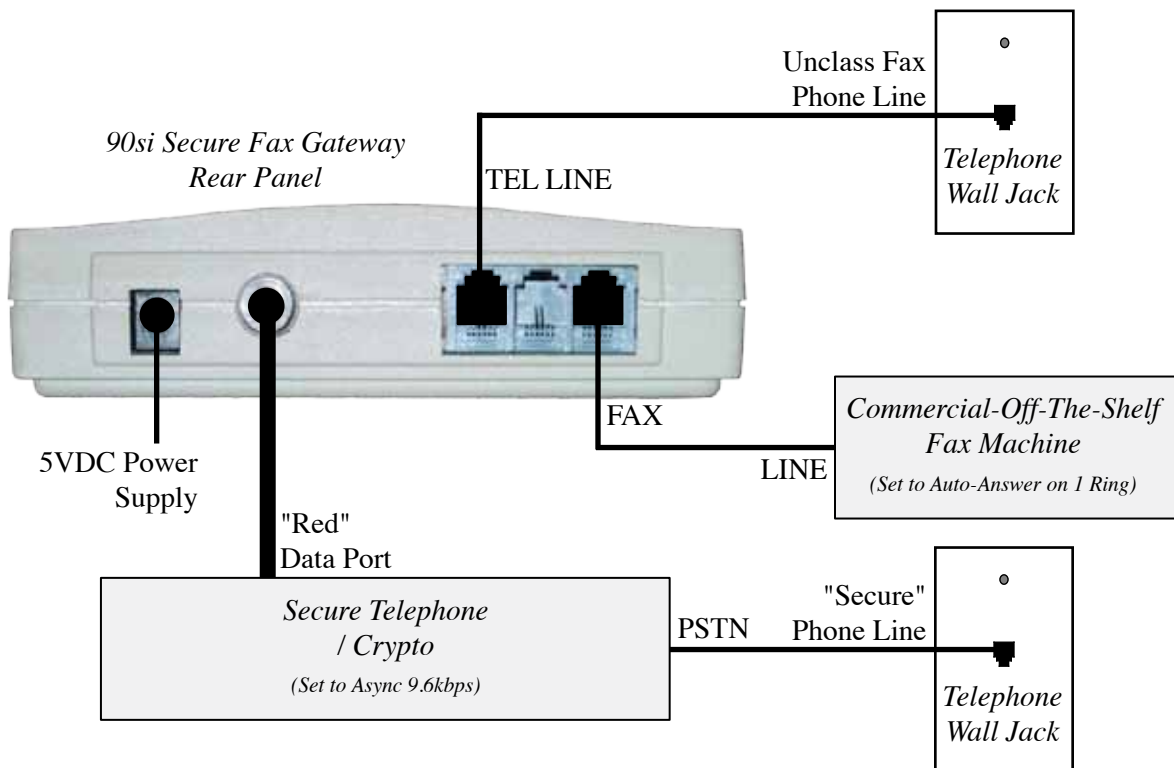

**Figure 2: 1-Line, Dual-Mode Configuration**

### 2.3.5 2-Line Dual-Mode

With this configuration your fax will function as your Primary non-secure fax as well as your Primary secure fax. It requires two separate phone lines, one is your unclassified fax number and the other is your classified phone number. Incoming Non-Secure fax calls will be answered automatically, as long as the fax is not otherwise processing a secure fax. All of the automatic functions of the COTS fax will work in Non-Secure mode.

**Set the Configuration to (03) 2-Line Dual-Mode.** See Section 2.4, Setting Your Chosen Configuration for instructions on how to do this.

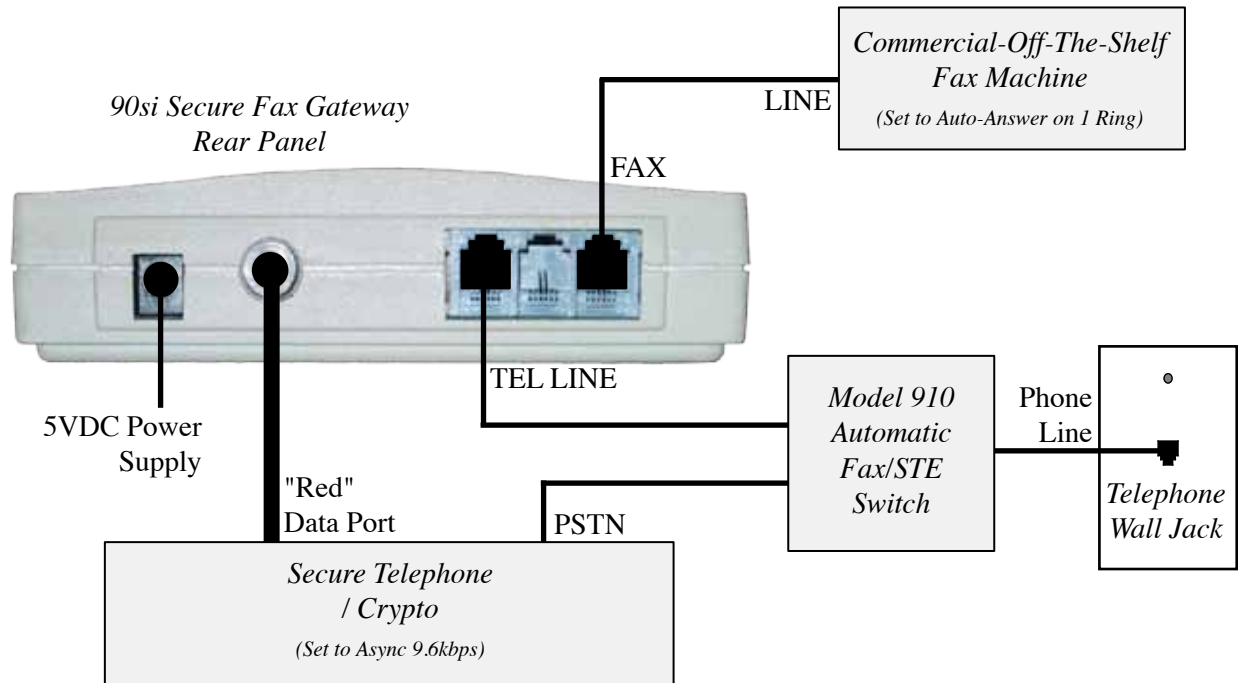

**Figure 3: 2-Line, Dual-Mode Configuration**

### 2.3.6 1-Line Dual-Mode with 910 Option

This configuration requires the optional Model 910 Auto Fax/STE Switch which allows your fax to function as both your Primary non-secure as well as your Primary secure fax while using only one telephone line. No operator need be present to receive a non-secure fax.

**Set the Configuration to (03) 2-Line Dual-Mode.** See Section 2.4, Setting Your Chosen Configuration, for instructions on how to do this.



**Figure 4: 1-Line, Dual-Mode with 910 Option Configuration**

### 2.3.7 1-Line Dual-Mode with an A/B Switch

This configuration is for use when the Commercial Fax will function as **Either** a Non-Secure Fax or a Secure Fax but not both without an operator actuating the A/B Switch. Use this for "Nite-Mode" operation when you want to receive unclassified faxes automatically when you are away.

For an Automatic Single-Line configuration see Section 2.3.6, 1-Line Dual-Mode with 910 Option, above.

**Set the Configuration to (03) 2-Line Dual-Mode.** See Section 2.4, Setting Your Chosen Configuration, for instructions on how to do this.

#### A/B Switch Operation:

**A:** Unclassified Fax Mode – With the switch in the "A" position, incoming calls will ring the fax. The Secure Telephone is disconnected and will not get dial-tone.

**B:** Secure Fax Mode – With the switch in the "B" position, incoming calls will ring the Secure Telephone. The fax is disconnected and will not get dial-tone.

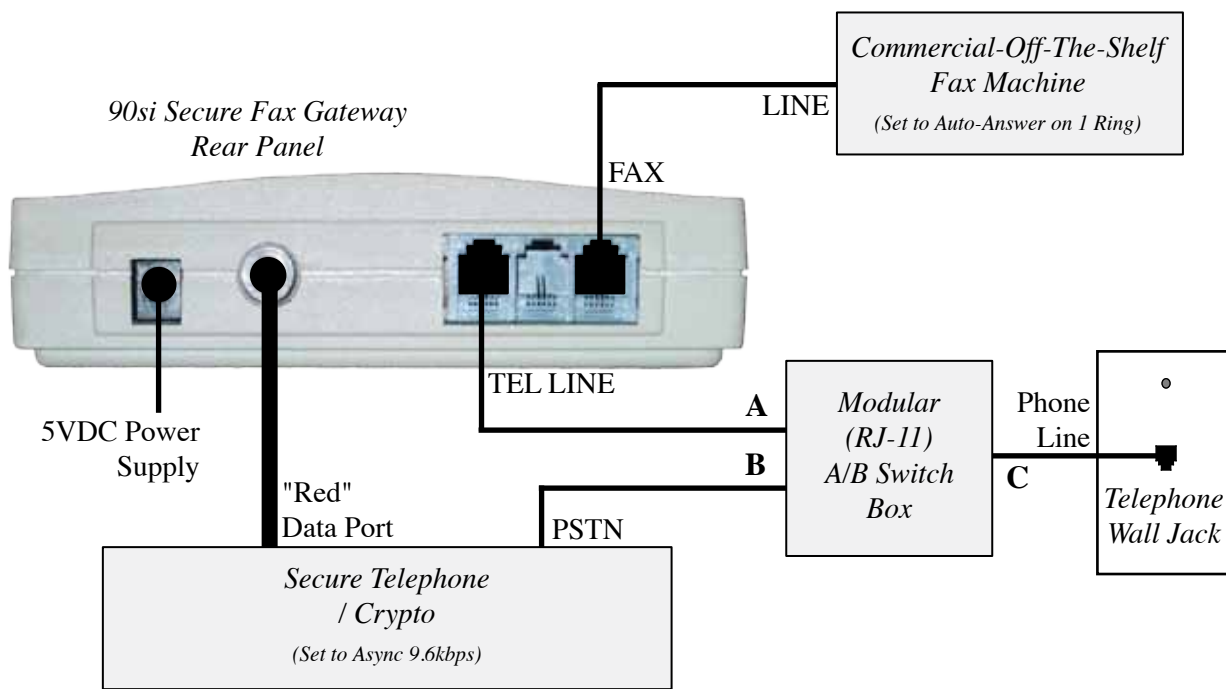

Figure 4: 1-Line, Dual-Mode with 910 Option Configuration

### 2.4 Setting Your Chosen Configuration

If you are using the Secure Only Configuration and your 90si is new from the factory, you need not set the configuration. If on the other hand your 90si is not factory new or you have chosen one of the Dual-Mode configurations you will need to tell the 90si what configuration you will be using. This is done using DTMF tones from the FAX dial pad while in the Default Settings mode. The configuration options and code numbers are shown below:

```
90si Default Settings List:
Configuration (select one)
->(01)<- Secure Only (factory default)
(02) 1-Line Dual-Mode
(03) 2-Line Dual-Mode
```

Entering the Default Settings mode is done with the Secure Telephone / Crypto idle (not in Secure Data mode) by pressing and holding the Reset button on the side of the 90si for five (5) to six (6) seconds until both Green and Red lights extinguish. Releasing the Reset button at this point will place the 90si into the Default Settings mode as evidenced by the Green light extinguished and the Red light illuminated. Changing the default protocol is then done using the attached fax machine's handset (or Hook button) and dial pad by dialing the two-digit code(s) of the setting(s) you wish to turn on or activate. The Secure Telephone / Crypto should be idle (not in Secure Data Mode). After dialing the two-digit code(s), hang up the fax to exit the Default Settings mode. The Green light will blink a number of times and then illuminate steadily. The 90si is now ready to operate with your new Default Settings.

The following example shows how to change the default configuration to 2-Line Dual-Mode (defined as configuration # 03)...

**With the Secure Phone idle (not in Secure Data mode) and only the Green "Power" light illuminated**

<u>Procedure</u>	<u>Response</u>
Press and hold the Reset button on the 90si	... until both the Green and Red lights extinguish, then...
release Reset	the Green light will be extinguished and the Red light illuminated
Take the fax off-hook	(you will hear dial-tone)
Press 0 and then 3 on the fax dial pad	you will hear a beep(s). (Note: 03 is the configuration code for 2-Line Dual-Mode. See the above Default Settings list for Secure Only, and 1-Line Dual-Mode.
hang up the fax	The Green light will blink a number of times. When it is illuminated steady the 90si will be ready and in the 2-Line Dual-Mode configuration.

**Notes:**

\*1 Most fax machines have a button that when depressed, returns dial-tone from the telephone system. This button is often labeled Hook, Manual Dial, Monitor, On Hook Dial or something to that effect. Find and use this Hook button on your fax or use the handset. If your fax does not have a handset or a hook button you will need to temporarily connect a plain old telephone to the TEL jack on the back of the fax machine to change Default Settings.

## 2.5 Print the Default Settings List

Currently this feature is unavailable but will be provided to you, at no charge, in a future remote software upgrade.

The factory Default Settings List is printed from the 90si to the attached COTS fax and looks like this.

```

90si Default Settings List:
Configuration (select one)
->(01)<- Secure Only (factory default)
    (02)  1-Line Dual-Mode
    (03)  2-Line Dual-Mode
Mode (select one)
    (04)  Half Duplex
->(05)<- Full Duplex
Protocol (select one)
    (06)  Async 2400 Bd

```

```
(07) Async 4800 Bd
->(08)<- Async 9600 Bd
(09) Async 19200 Bd
(10) Mil STD Handshake w/o FEC
(11) Mil STD Handshake w/FEC
(12) Mil STD Broadcast w/o FEC
(13) Mil STD Broadcast w/FEC
Misc.: (select any)
->(16)<- STE Connected
(17) OMNI, Sectera, vIPer, other Connected
```

## 2.6 Setting Up Your Encryption Device

The following sections provide step-by-step procedures for setting your secure telephone / encryption device for Asynchronous 9600bps secure data mode.

### 2.6.1 L-3 Secure Terminal Equipment (STE)



**Objective:** To set the Secure Signalling Mode to SCIP, Secure Data Mode to Asynchronous 9.6 Kbps and SCIP Line Quality to Normal

**Set your 90si Default Settings to:** (05) Full Duplex, (08) Async 9600, (16) STE Connected and your chosen configuration (See Section 2.3 Choose a Configuration).

For STE's with software V2.4 and later:

**While On-Hook** (to permanently set)

<b>Press</b>	<b>Display</b>
MODE	SECURE SIGNALLING MODE: SCIP
SCROLL	SECURE DATA: /STU SECURE VOICE (shows current secure data and secure voice settings)
CHANGE	(Example) SECURE DATA: S19.2 (Synchronous, 19.2Kbps) (shows current secure data settings)
CHANGE (until)	SECURE DATA: Asynchronous
SCROLL	(Example) SECURE DATA: 19.2 Kbps
CHANGE (until)	SECURE DATA: 9.6 Kbps
SCROLL (until)	SCIP LINE QUALITY: LOW (Example)
CHANGE (until)	SCIP LINE QUALITY: Normal
SCROLL	
MODE	(blank display)

Note that to permanently set the Secure Data mode, the handset must be on-hook. If you do these procedures with the handset off-hook, the changes hold for the current call only. When you hang up, the Secure Data settings will revert to the previous settings.

## 2.6.2 L-3 OMNI / OMNIxi



**Objective:** To set the Secure Data mode to PSTN, Async, 9600 bps.

**Set your 90si Default Settings to:** (05) Full Duplex, (08) Async 9600, (17) OMNI, Sectera, vIPer, other Connected and your chosen configuration (See Section 2.3 Choose a Configuration).

Apply power to the omni and login as an Authorized User <AU> or Terminal Administrator <TA>...

<b>Press</b>	<b>Display</b>
(logon) ENTER	LOGON SUCCESSFUL
MENU	<TA MENU> / 0-EXIT TA MODE / 1-ZEROIZE
2, ENTER	<OMNI CONFIG> / 1-TERM CONTROL / 2-SET NETWORK
2, ENTER	(Example) NET: PSTN-SYNC / 1-PSTN ASYNC / 2-PSTN-SYNC
1	NET: PSTN-ASYNC
ENTER	
BACK	<OMNI CONFIG> / 1-TERM CONTROL / 2-SET NETWORK
6, ENTER	(Example) Async 19200 bps
3, ENTER	Async 9600 bps
MENU	(to exit)

If your OMNI / 90si does not work after you make the above changes, confirm the following setting. To view these settings press the Menu button followed by each individual code digit followed by Enter. For example, 2,1 would be Menu, 2, Enter, 1, Enter to view the Term Control setting.

<b>Code</b>	<b>Setting</b>	<b>Code</b>	<b>Setting</b>
2,1	Term Control = Local	2,14	Signaling = STANDARD
2,2	Set Network = PSTN ASYNC	3,1	SEC Settings/Secure Mode = Traditional
2,4	Set LCL Port = EIA232	3,2,1	SEC/SACS Voice/Secure Voice = ENBL
2,6	Set Rate = ASYNC 9.6 kbps	3,2,4	SEC/SACS Voice/ACL SEC Voice = DSBL
2,7,1-4	CLK Polarity = (set all to Normal)	3,3,1	SEC/SACS Data/Secure Data = ENBL
2,12	DTE TX CLK = OMNI	3,3,4	SEC/SACS Data/ACL SEC Data = DSBL
2,13	RESYNC INTRVL = DSBL		

**Required L-3 provided LDI Red Data Cable:** Each OMNI ships with a Local Data Cable, L-3 part number K10048260-4. One end of this cable terminates in a DB25 connector (into which the 90si plugs), the other connects to the "Local Data" connector on the back of the OMNI/OMNIxi.

### 2.6.3 General Dynamics Sectera Wireline Terminal



**Objective:** To set the Secure Data mode to Async, 9600 bps.

**Set your 90si Default Settings to:** (05) Full Duplex, (08) Async 9600, (17) OMNI, Sectera, vIPer, other Connected and your chosen configuration (See Section 2.3 Choose a Configuration).

## 2.6.4 General Dynamics Sectera vIPer



**Objective:** To set the Red Data Port to 9600 bps.

**Set your 90si Default Settings to:** (05) Full Duplex, (08) Async 9600, (17) OMNI Sectera vIPer other Connected and your chosen configuration (See Section 2.3 Choose a Configuration).

Insure the following vIPer settings:

<b>Item</b>	<b>Setting</b>
Secure Data	Enabled
Red Data Port Rate	9600 bps.
Auto-Answer Data	Disabled (Enabled for unattended reception of secure faxes)
Auto Lock	OFF

The vIPer Red Data Port has a 9-pin D type connector while the 90si ships with a Female DB25 Data Port connector. A cable adapter is required as described in the following table.



---vIPer Side---			---90si Side---	
<b>vIPer</b>	<b>DB9M</b>	<b>Direction</b>	<b>DB25F</b>	<b>90si</b>
TXD	3	<---	2	TD
RXD	2	-->	3	RD
RTS	4	<--	4	RTS
CTS	8	-->	5	CTS
DSR	6	-->	6	DSR
DTR	4	<--	20	DTR
GND	5	---	7	SD

**NOTE:**

These pin-outs represent industry standard 9-pin to 25-pin serial data interconnect. Such adapters are widely available.

## 2.6.5 Motorola STU-IIB & STU-III A



**Objective:** To set Secure Data Mode for 2.4/9.6 Kbps, Full Duplex, Synchronous for use with Mil-Std-188-161/ STANAG 5000 protocols only.

**Set your 90si Default Settings to:** (05) Full Duplex, (10) Mil STD Handshake w/o FEC, (17) OMNI Sectera vIPer other Connected and your chosen configuration (See Section 2.3 Choose a Configuration).

**While Off-Hook and in CLEAR mode:**

<b>Press</b>	<b>Display</b>
PRGM	(Example) DATA = 2400 ASYNC
SCROLL (until...)	DATA = SYNCHRONOUS
PRGM	PRGM (current call status displayed)

**While On-Hook:**

<b>Press</b>	<b>Display</b>
PRGM	PRGM (enunciator in display)
SCROLL	PLEASE WAIT (and then) # for COMSEC * TO SET OPTIONS
*	PRESS SCROLL TO CONTINUE
SCROLL (until...)	(Example) DATA=2400 ASYNC # TO CHANGE
#	DATA=SYNCHRONOUS # TO CHANGE
PRGM	PRGM (current call status displayed)

**Note:**

Make sure that "HD" DOES NOT appear in the display. If it does, press the "HALF-DUPLEX" button to make it disappear.

## 3.0 Using your 90si

### 3.1 Applying Power

The Easy-Fax 90si STU-III Gateway uses an external power supply. Since the 90si has no ON/OFF switch, the device is "on" as soon as power is applied. To confirm that the 90si is properly powered and ready to operate, ensure that the Green "POWER" light is illuminated and that the Red "FAULT" indicator is extinguished.

### 3.2 Sending a Secure Fax

Use the following, generic, procedure to send a secure fax. You may want to make a version for your secure phone and COTS fax that references the appropriate details.

<u>Step</u>	<u>Procedure</u>
1.	Place a call on your secure telephone / crypto.
2.	Place it in secure data mode and set the handset on the table
3.	Load your document in the facsimile
4.	Take the fax machine "off-hook", dial a "1" and press the big Start or Sent button (this will use the default transmit protocol)
5.	The fax will begin sending pages, one at a time, and will indicate when it's done, usually with a beep.
6.	When the fax is done, you may return the call to Secure or Clear Voice or disconnect.

#### Off-Hook

Most fax machines have a button that when depressed, returns dial-tone from the telephone system. This button is often labeled Hook, Manual Dial, Monitor, On Hook Dial or something to that effect. If your fax only has a handset lift it off-hook, dial a "1" and press the Start button and then hang it back in its' cradle. If your fax does not have a handset or a hook button (many HP faxes don't) simply eliminate this step (i.e. use 1, Start).

#### Secure/Non-Secure Differentiation

Secure faxes are always initiated from the secure phone / crypto and then the secure phone is placed in secure data mode for the duration of the secure fax transmission. The 90si will not allow public faxes to be initiated from the secure phone / crypto.

### 3.3 Receiving a Secure Fax

**Important:** Your commercial fax device MUST be set to auto-receive as a fax for your 90si system to work properly. Additionally, make sure that your fax is set to auto-answer on the fewest number of rings it will allow. Ideally one or two rings. (See your faxes manual).

<u>Step</u>	<u>Procedure</u>
1.	Answer the incoming call on your secure telephone
2.	Place it in secure data mode (either end may do this)
3.	Standby, the fax will be received automatically
4.	When the fax is done, you may return the call to Secure or Clear Voice or disconnect

### 3.4 Sending a Public Fax (Dual-Mode Configurations Only)

To send a public (unclassified) fax, simply place the call as you normally would using the fax machine handset, hook button (speakerphone) or one of its' programmed auto-dial buttons.

Note: The 90si will not allow you to send a public facsimile while the secure telephone is in the secure data mode.

### 3.5 Receiving a Public Fax (Dual-Mode Configurations Only)

Receiving a public (unclassified) fax differs depending on whether you are using one or two telephone lines. Please insure that your COTS fax set to auto-answer as a fax on 1 or 2 rings.

With a **Two-Line Dual-Mode** configuration, public (unclassified) faxes will be received unattended.

With a **One-Line Dual-Mode** configuration the following procedure applies:

<b>Step</b>	<b>Procedure</b>
1.	Answer the incoming call on your secure telephone
2.	Once the caller indicates a public fax document, is forthcoming, depress the "asterisk" (*) key on the secure telephone <u>twice</u>
3.	Standby as the fax is received and printed

### 3.6 90si Status Lights

The 90si has two rectangular LED's protruding from the front of the unit as shown in this picture. One is green and is labeled (on the bottom of the unit) POWER, the other is red and is labeled FAULT. They are used together to indicate different status and error conditions as described below.

#### Power-up:

Note: Before applying power to the 90si, make sure that all cables are securely connected and that your commercial fax device is in Auto-Receive (Fax) mode and answers on 1 or 2 rings.

There are a series of LED indications during the 90si power-up sequence. Before power is supplied to the unit, both LED's will be extinguished. When power is initially applied, the green "POWER" LED will flash intermittently indicating that a self-test is in progress. Once self-test is successfully completed, the green "POWER" LED will illuminate. The 90si is now in the "ready" state.

#### Communication Errors:

If an error occurs during a reception or transmission of a fax, the red "FAULT" LED will illuminate. This indicates that a communications error has occurred. The unit will still operate. The red "FAULT" LED will go out after 90 seconds or once a new transmission begins.

#### System Errors:

Flashing green and red LED's indicate that the 90si has detected an internal failure during self-test at power up, or during normal operation of the unit. If this occurs, press the white "RESET" button located on the right side of the unit. This will restart the 90si and should return it to the "ready" state (green "POWER" LED on, red "FAULT" LED off). If it does not, depress the "RESET" button a second time. If this is ineffective, unplug the unit from the wall, wait a moment, and plug it back in.



### 3.7 Selecting a Transmit Protocol

As always, the 90si automatically determines and switches to the correct protocol as a receiver. So, as usual, you must select the transmit protocol that you wish to use. There are two ways to do this; using the Default Protocol Setting (Send via HOOK, 1, START) or by manually dialing the appropriate transmit protocol's One-Time Code as you are sending the fax (Send via HOOK, "One-Time Code", START). When using the One-Time Codes, insure that your Secure Phone / Crypto's Secure Data mode is set correctly for the mode you choose (Sync or Async & Baud Rate).

The 90si supports two different secure fax protocols plus a few subsets; SCIP Async and Mil-Std-188-161 (synchronous). With the Async protocol the user must select a baud rate or speed of which the 90si supports four; 2400, 4800, 9600 and 19200 bps. The Mil-Std-188-161 protocol has four subsets; Handshake with FEC, Handshake w/o FEC (recommended), Broadcast with FEC and Broadcast w/o FEC. As the Mil-Std-188-161 modes are synchronous, baud rate selection is automatic.

The 90si's factory default protocols is Asynchronous 9600bps.

#### 3.7.1 SCIP Async Protocol

The Async protocol has been around since the late 1980's, however it has never been widely used until the production release of the KSV-21 Crypto Card for the STE. The KSV-21 does not support synchronous secure data modes when the STE is connected to a PSTN line. While it does support synchronous when connected to an ISDN line, the overwhelmingly large number of STE's connected to PSTN lines will drive most secure fax users to this mode. As a result, the 90si comes with the Async Protocol (with a baud rate of 9600 bps) set as the factory default. The 90si supports Async baud rates of 2400, 4800, 9600 and 19,200 bps (bits per second).

#### 3.7.2 Mil-Std-188-161 Protocols (Synchronous)

As mentioned earlier, the 90si implements four flavors of the synchronous Mil-Std-188-161 protocol:

##### **Handshake with FEC Off**

This is the only Mil-Std-188-161 protocol we recommend for use with desktop (non Tactical) cryptographic devices such as the STE, OMNI and SECTERA. The handshaking that it gets its' name from come in the form of "acknowledgements" from the receiving fax machine which occur at the beginning of the transmission and between each page. Forward Error Correction (FEC) is not necessary with these cryto devices because they provide their own, quite effective, error correction.

##### **Handshake with FEC On**

As described above but with FEC turned on. This error correction technique adds about 20% more data to the image data but allows operation on noisy communications links with a Bit Error Rate of up to  $10^{-2}$ .

##### **Broadcast with FEC Off**

The broadcast mode was designed for point-to-multipoint battlefield radio networks and is a poor choice for modern secure telephone networks. Requiring no response from the receiving secure fax, the sending secure fax has no way of knowing if the transmission was received.

##### **Broadcast with FEC On**

As described above but with FEC turned on.

#### 3.7.3 Full and Half Duplex

Full Duplex is the factory default setting and the recommended setting for most crypto devices including STE, Omni, Sectera vIPer and Wireline Terminals, KIV-7, KG-84 as well as STU-IIB and STU-III A.

The 90si's Half-Duplex setting was specifically designed for use with PTT (Push To Talk) radio devices such as the Harris PRC-117, Motorola LST-5 and the Raytheon PSC-5 at 16Kbps using the Mil STD Broadcast w/o FEC protocol. With (04) Half Duplex selected, the RTS (Request To Send) lead is used to generate the PTT signal and only goes active when the 90si has data to send, returning to the inactive state otherwise. If you wish to use your 90si with such PTT radio systems, please contact us at 1-877-951-9800 or 804-796-1900.

### 3.8 Setting and Using the Default Transmit Protocol

There are two ways to tell the 90si what protocol you wish it to use when transmitting a secure fax. One way is using the Default Protocol Settings described in this section and the other is using the One-Time Codes described in the next section.

The Default Transmit Protocol is factory set to Async 9600 bps and is employed during a normal 90si transmission by taking the fax off-hook, dialing a "1" on the dial pad and pressing the Start or Send button. The off-hook step may be omitted if you fax does not have a Hook, Manual Dial, Monitor or On Hook Dial button (or its' equivalent). The default settings are indicated on the 90si Default Settings List, an example of which is shown below.

```
90si Default Settings List:
Configuration (select one)
->(01)<- Secure Only (factory default)
  (02)  1-Line Dual-Mode
  (03)  2-Line Dual-Mode
Mode (select one)
  (04)  Half Duplex
->(05)<- Full Duplex
Protocol (select one)
  (06)  Async 2400 Bd
  (07)  Async 4800 Bd
->(08)<- Async 9600 Bd
  (09)  Async 19200 Bd
  (10)  Mil STD Handshake w/o FEC
  (11)  Mil STD Handshake w/FEC
  (12)  Mil STD Broadcast w/o FEC
  (13)  Mil STD Broadcast w/FEC
Misc.: (select any)
->(16)<- STE Connected
  (17)  OMNI, Sectera, vIPer, other Connected
```

The list is broken into four sections: Configuration, Mode and Protocol and Misc. The arrows (-> <-) point to the item that is currently selected. In the above list, the Configuration is set to Secure Only, the Mode is Full Duplex and the default Protocol is Async 9600 Bd (baud or bits per second). In each section, only one item can be selected at a time.

Entering the Default Settings mode is done by pressing and holding the Reset button on the side of the 90si for five (5) to six (6) seconds until both Green and Red lights extinguish. Releasing the Reset button at this point will place the 90si into the Default Settings mode as evidenced by the Green light extinguished and the Red light illuminated. Changing the default protocol is then done using the attached fax machine's handset (or Hook button) and dial pad by dialing the two-digit code(s) of the setting(s) you wish to change. The Secure Telephone / Crypto should be idle (not in Secure Data Mode). After dialing the two-digit code(s), hang up the fax to exit the Default Settings mode. The Green light will blink a number of times and then illuminate steadily. The 90si is now ready to operate with your new Default Settings.

The following example shows how to change the default protocol to "Mil STD Handshake w/o FEC" (defined as protocol 10)...

With the Secure Phone idle and only the Green "Power" light illuminated:

<b><u>Procedure</u></b>	<b><u>Response</u></b>
Press and hold the Reset button on the 90si	... until both the Green and Red lights extinguish, then...
release Reset	the Green light will be extinguished and the Red light illuminated
Take the fax off-hook *1	(you will hear dial-tone)
10 on the fax	you will a beep. (Note: 10 is the protocol code for Mil STD Handshake w/o FEC. See the above list for the other codes.)
hang up the fax	The Green light will blink a number of times. When it illuminated steady the 90si is ready send using the Mil STD Handshake w/o FEC protocol.

**Notes:**

\*1 Most fax machines have a button that when depressed, returns dial-tone from the telephone system. This button is often labeled Hook, Manual Dial, Monitor, On Hook Dial or something to that effect. Find and use this Hook button on your fax or use the handset. If your fax does not have a handset or a hook button you will need to temporarily connect a plain old telephone to the TEL jack on the back of the fax machine to change Default Settings.

### 3.9 Using a One-Time Transmit Protocol Code

A one-time protocol code allows you use a different protocol (than the default setting) for the current transmission only. The default protocol setting is not effected or changed. To use a One-Time protocol; get into secure data mode with the unit you want to send to, take the fax off-hook, dial the desired One-Time Code and press the Start or Send button. Once your crypto cycles back out of Secure Data mode, the 90si will return to the default settings.

<b><u>Code</u></b>	<b><u>One-Time Transmit Protocol</u></b>
*10	Async 2400
*11	Async 4800
*12	Async 9600
*13	Async 19,200
*14	Mil-Std-188-161 Handshake w/o FEC (Sync)
*15	Mil-Std-188-161 Handshake with FEC (Sync)
*16	Mil-Std-188-161 Broadcast w/o FEC (Sync)
*17	Mil-Std-188-161 Broadcast with FEC (Sync)

## 4.0 If There's a problem

### 4.1 How Will You Know

#### **The 90si Front Panel LED's**

If the 90si encounters a problem during fax communication, the red "FAULT" LED on the front panel will illuminate. If this occurs, there is no need to reset the unit. The indicator will extinguish automatically.

#### **Indicators On Your Fax Machine**

Additional error indications may be displayed by your fax machine. These will usually be in the form of an audible alarm (a "beep") or visual indicator (a light or alpha-numeric display). Consult your fax machine user's manual for explanations of alarm conditions and how to restore normal operation.

#### **Find Your COTS Fax Manual Here**

If you do not have a manual for your COTS fax machine, we maintain links on our web site that will help you find an electronic copy: <http://www.gwfs.com/Header/TechnicalHelp/FaxManuals.html>

### 4.2 Troubleshooting Tips

There are a number of places from which a problem could originate, including the COTS fax settings, the 90si settings and wiring and the settings and wiring of the local cryptographic device. We will address common issues below:

#### **Fax Auto-Answer**

Insure that the fax is set to automatically answer, as a fax, on the fewest number of rings possible (2 rings max). The way this is indicated will vary by machine -- some have an "auto answer" button and/or light that should be illuminated; others might say "fax" in the display (not "fax/tel or TAD, etc.) and usually have a button called "answer mode" (or something like that) that when depressed, cycles the machine through "fax", "manual", "tel/fax" and "TAD". If you are unsure of this setting for your machine, call or e-mail us and we will help you figure it out.

#### **90si Configuration**

The 90si comes from the factory set to the Secure Only configuration. This is the simplest and safest configuration. Insure that your 90si is wired in the way demanded by the configuration of your choice.

#### **Secure Data Mode**

Your STE (or other crypto device) needs to be set for Async 9600 (for most applications). Please insure that this is the case. If it is not set properly for the default or one-time protocol you are using, the secure fax transaction will fail.

#### **Interconnect Cables**

Insure that all of the cables that connect to the COTS fax, 90si and Secure Telephone are seated properly. It might be a good idea to remove each of them, one at a time, and re-seat the connectors.

#### **Make a Copy**

This is an easy test that exercises much of the electronics and all of the mechanical parts of the fax machine. If it does not make a copy properly, then the problem is in the fax itself.

#### **Place a Call on the STE or Secure Phone**

Do you get a dial-tone and can you call and talk with another STE or Secure Phone in Secure Voice mode? Can you transition the call into the Secure Data mode?

**Send and Receive a Public Fax**

Insure that you can send and receive a public fax. If you are using the Secure Only configuration, temporarily disconnect the fax from the 90si and connect it directly to the outside phone line. When you test receiving a fax, be sure to listen to how many rings occur before the fax answers. You should hear between 0 and 2 rings.

**4.3 When All Else Fails...Call Our Help Line**

If your problems persist, gather the following information and call us.

90si Serial Number

Brand and Model Number of your COTS fax.

Brand and Model Number of the Secure Telephone / Crypto

Your Secure and Public Fax Phone Numbers

Your Configuration Settings.

Call our Secure Fax Help Line at 1-877-951-9814 (toll free) or 336-697-9100 from your Secure telephone. We are fully equipped and staffed to test and diagnose your problem over the phone -- answer any of your questions and get your system operational quickly. And best of all, technical support is free and unlimited.

**5.0 Warranty Information**

Gateway Fax Systems, Inc. warrants the 90si to be free from defects in materials and workmanship under normal use for a period of one (1) year from the date of delivery as evidenced by a copy of the sales receipt. GWFS will, at its option, repair or replace the unit at no charge provided:

- a) The unit was not damaged due to misuse or abuse.
- b) You contact GWFS by phone, toll-free, at 1-877-951-9800 or e-mail at help@gwfs.com and receive a return authorization number.
- c) You ship your 90si prepaid to GWFS. GWFS will pay return freight via UPS 2nd Day Air.
- d) We will return the unit to working order and ship it back out within one business day of receiving it.

NO OTHER WARRANTIES ARE EXPRESSED OR IMPLIED INCLUDING IMPLIED WARRANTIES OF MERCHANTABILITY OR FITNESS FOR A PARTICULAR PURPOSE.

**6.0 Specifications****6.1 General Specifications****Compatible Secure Phones / Cryptos**

STE, OMNI, OMNIxi, vIPer, Sectera SWT, KIV-7, STU-II, STU-IIB, STU-IIIA, STU-III, KG-84, and other secure telephones/cryptos.

**Physical Interfaces (five)**

1) Secure Telephone (DB-25F/RS-232 Digital), 6' integral cable; 2) Secure Telephone (RJ-11C Analog); 3) Phone Line (RJ-11C); 4) COTS Fax (RJ-11C); 5) Power from supplied AC power supply (see below)

**Transmission Rate**

Secure: 2400, 4800, 9600 bps sync & 2400, 4800, 9600, 19200 bps async, Non-Secure: Imposes no restrictions.

**Supported Protocols**

SCIP Async (2.4, 4.8, 9.6 and 19.2 Kbps), Mil-Std-188-161 Sync Type 1, STANAG 5000 Type 1 (less 16kbps and uncompressed), CCITT Group 3 (T30, T4).

### **Secure Fax Compatibility**

Secure faxes made by: Cryptek, Ilex, Ricoh, TSP/GTE (now Gateway Fax Systems), AN/UXC-7, all MIL-STD-188-161 and NATO STANAG 5000 faxes.

### **Regulatory Approvals**

FCC Part 15/68, DISA JITC (Ft. Huachuca, AZ) re-certified 18 JAN 99

### **Environmental**

Temp: 10 to 40 C, Humidity: 20-80% RH

### **Electrical**

Input 5 VDC, 6.2 W max., 2.7 W idle.

### **External Power Supply**

Input: 100-240 VAC Auto Sensing, 50-60 Hz, Output: 5 VDC, 4A Regulated, Phys: 4x2.5x1.7 in, .75 Lb, Regulatory: UL, cUL, CE

### **Physical**

90si: 5.52" x 5.52" x 1.5" (WxHxD), 1 lb, 2.5 oz; shipping box: weight 3.5 Lb, 12.5" x 8.5" x 4.5"

### **Standard Warranty**

1 year parts-and-labor

### **Included in the Box**

90si with integral 6' long shielded data cable w/DB-25F connector, 6' long modular telephone cord, User's and Reference guides, power supply, AC power cord, adhesive velcro strip

### **Technical Support**

Unlimited, free, technical support for 90si, whatever fax you use and your secure phone.

## **6.2 Digital Interface Specifications**

The 90si's digital interface cable is a 6' long, shielded, RS-232 cable, captive to the 90si and terminated in a DB-25 male connector. The ten pins that the 90si uses are described below. The remaining pins are un-terminated, even if the pin positions are not. Output drivers provide +/- 6 VDC with 3K ohm loads on all outputs.

90si Digital Interface Pin-Assignments			
<b>Pin #</b>	<b>ID</b>	<b>Description</b>	<b>Direction</b>
1	FG	Frame Ground (sheild)	
2	TD	Transmit Data	Output
3	RD	Receive Data	Input
4	RTS	Request To Send	Output
5	CTS	Clear To Send	Input
6	DSR	Data Set Ready	Input
7	SG	Signal Ground	
15	TC	Transmit Clock	Input
17	RC	Receive Clock	Input
20	DTR	Data Terminal Ready	Output

## 7.0 Related Web Links

We have provided a few useful weblinks below:

Model 90si Secure Fax Gateway:	<a href="http://www.gwfs.com/90si.html">http://www.gwfs.com/90si.html</a>
90si Presentations and Images:	<a href="http://www.gwfs.com/90si/more.html">http://www.gwfs.com/90si/more.html</a>
90si Choices:	<a href="http://www.gwfs.com/Choices/90sichoices.html">http://www.gwfs.com/Choices/90sichoices.html</a>
90si User's Guide in PDF format:	<a href="http://www.gwfs.com/Header/TechnicalHelp/90siusers.pdf">http://www.gwfs.com/Header/TechnicalHelp/90siusers.pdf</a>
Model 690 Mid-Volume Secure-Fax System:	<a href="http://www.gwfs.com/690.html">http://www.gwfs.com/690.html</a>
Model 390 Low-Volume Secure-Fax System:	<a href="http://www.gwfs.com/390.html">http://www.gwfs.com/390.html</a>
Company Information:	<a href="http://www.gwfs.com/Footer/Moved.html">http://www.gwfs.com/Footer/Moved.html</a>
Technical Help:	<a href="http://www.gwfs.com/Header/TechnicalHelp/help.html">http://www.gwfs.com/Header/TechnicalHelp/help.html</a>
Complete Price List:	<a href="http://www.gwfs.com/Header/order.html">http://www.gwfs.com/Header/order.html</a>
Product Selection Chart:	<a href="http://www.gwfs.com/Header/chart.html">http://www.gwfs.com/Header/chart.html</a>
Frequently Asked Questions:	<a href="http://www.gwfs.com/Header/faq.html">http://www.gwfs.com/Header/faq.html</a>
DISA/JITC Certification:	<a href="http://www.gwfs.com/JITCCertification/JITCcert.html">http://www.gwfs.com/JITCCertification/JITCcert.html</a>
US Gov't SecurePhone Website:	<a href="https://www.iad.gov/securephone/index.cfm">https://www.iad.gov/securephone/index.cfm</a>
GD Sectera Wireline Terminal:	<a href="http://www.gdc4s.com/content/detail.cfm?item=87249ff2-22ae-478f-a483-a475b5dd0a8d">http://www.gdc4s.com/content/detail.cfm?item=87249ff2-22ae-478f-a483-a475b5dd0a8d</a>
GD vIPer:	<a href="http://www.gdc4s.com/content/detail.cfm?item=0f71db22-0eb9-413d-b144-8eea7c767e64">http://www.gdc4s.com/content/detail.cfm?item=0f71db22-0eb9-413d-b144-8eea7c767e64</a>
L-3 Omni:	<a href="http://www.l-3com.com/cs-east/ia/omni/ie_ia_omni.shtml">http://www.l-3com.com/cs-east/ia/omni/ie_ia_omni.shtml</a>
L-3 STE:	<a href="http://www.l-3com.com/cs-east/ia/ste/ie_ia_ste.shtml">http://www.l-3com.com/cs-east/ia/ste/ie_ia_ste.shtml</a>

## 8.0 Safety Information and FCC Requirements

### Important Safety Instructions:

1. Read and understand all instructions.
2. Follow all warnings and instructions marked on the product.
3. Unplug this product from the wall outlet before cleaning. Do not use liquid cleaners or aerosol cleaners.

- Use a damp cloth for cleaning.
4. Do not use this product near water, for example, near a bathtub, wash bowl, kitchen sink, or laundry tub, in a wet basement, or near a swimming pool.
  5. Do not place this product on an unstable cart, stand or table. The product may fall causing serious damage to the product.
  6. This product should never be placed near or over a radiator or heat register. This product should not be placed in a built-in installation unless proper ventilation is provided.
  7. This product should only be powered from the type of power source indicated on the marking label. If you are not sure of the type of power supply to your facility, consult your dealer or local power company.
  8. This product is equipped with a three wire grounding type plug, a plug having a third (grounding) pin. This plug will only fit into a grounding type power outlet. This is a safety feature. If you are unable to insert the plug into the outlet, contact your electrician to replace your obsolete outlet. Do not defeat the safety purpose of the grounding type outlet.
  9. Do not allow anything to rest on the power cord. Do not locate this product where the cord will be abused by persons walking on it.
  10. Do not overload wall outlets and extension cords as this can result in the risk of fire or electric shock.
  11. Never spill liquid of any type on the product.
  12. To reduce the risk of electric shock, do not disassemble this product, but send it to a qualified service facility when some service or repair work is required. Opening or removing covers may expose you to dangerous voltages or other risks. Incorrect reassembly can cause electric shock when the unit is subsequently used.
  13. Unplug this product from the wall outlet and refer servicing to qualified service personnel under the following conditions:
    - A. When the power supply cord or plug is damaged or frayed.
    - B. If liquid has been spilled into the product.
    - C. If the product has been exposed to rain or water.
    - D. If the product does not operate normally by following the operating instructions. Adjust only those controls that are covered by the operating instructions because improper adjustment of other controls may result in damage and will often require extensive work by a qualified technician to restore the product to normal operation.
    - E. If the product has been dropped or the cabinet has been damaged.
    - F. If the product develops a distinct change in performance.
  14. Avoid using a telephone (other than a cordless type) during an electrical storm. There may be a remote risk of electric shock from lightning.
  15. Do not use the telephone to report a gas leak in the vicinity of the leak.

### **Consumer Information and FCC Requirements:**

- This equipment complies with Part 68 of the FCC rules. On the bottom of the base of this equipment is a label that contains, among other information, the FCC Registration Number and Ringer Equivalence Number (REN) for this equipment. You must upon request, provide this information to your telephone company.
- The REN is useful to determine the quantity of devices you may connect to your telephone line and still have all of those devices ring when your telephone number is called. In most, but not all areas, the sum of the REN's of all devices connected to one line should not exceed five (5.0). To be certain of the number of devices you may connect to your line, as determined by the REN, you should contact your local telephone company to determine the maximum REN for your calling area.
- If your 90si causes harm to the telephone network, the telephone company may discontinue your service temporarily. If possible, they will notify you in advance. But if advance notice isn't practical, you will be notified as soon as possible. You will be informed of your right to file a complaint with the FCC.

- Your telephone company may make changes in its facilities, equipment, operations or procedures that could affect the proper functioning of your equipment. If they do, you will be notified in advance to give you an opportunity to maintain uninterrupted telephone service.
- If you experience trouble with the 90si, there are no repairs that can be made by the customer. For repair/warranty information please contact:

GWFS Customer Service

<http://www.gwfs.com>

[help@gwfs.com](mailto:help@gwfs.com), 1-877-951-9800

The telephone company may ask that you disconnect this equipment from the network until the problem has been corrected or until you are sure that the equipment is not malfunctioning.

- This equipment may not be used on coin service provided by the telephone company. Connection to party lines is subject to state tariffs.
- Current FCC regulations specify that any direct connections to a telephone company line be done using only standard phone jacks and plugs that meet FCC regulations.

## 9.0 Glossary

Listed below are definitions of words and terms used in the 90si User's and Reference Guides.

### **Asynchronous**

Async for short, Asynchronous refers to the way in which data is passed between the 90si and the attached Secure Phone. Specifically, no physical "clock" signal is generated by the Secure Phone. Instead, the timing data is embedded in the data and must be decoded by the 90si and the far end secure fax.

### **Broadcast**

A signaling option in the Mil-Std-188-161 mode in which the transmitting device does not look for any acknowledgements during a fax transmission.

### **Commercial Fax Device**

A Commercial-Off-The-Shelf (COTS) "standard" Group III fax machine or computer-based fax device.

### **Configuration**

For the purposes of this document, Configuration refers to the various ways in which the 90si can be connected together with the fax, secure telephone and outside phone line to provide differing sets of secure and non-secure fax and voice functions. See also, Secure Only, 1-Line Dual-Mode and 2-Line Dual-Mode.

### **Data Port (see also Red Data Port)**

The term Data Port refers to the RS-232 serial interface on the crypto device to which the 90si's "STE" cable connects. It is also referred to as a Red Data Port.

### **Dual Mode**

A 90si configuration which allows the local fax machine to communicate with both secure and commercial fax machines.

### **ECC**

The KSV-21 ECC (Enhanced Crypto Card) used in the STE, contains the SCIP cryptographic engine.

### **FEC (Forward Error Correction)**

An option available in the Mil-Std-188-161 mode that can decrease errors in fax transmission over noisy communication lines. Note that STU's provide "clean" communication lines therefore eliminating the need for FEC.

### **Handshake**

A signaling option in the Mil-Std-188-161 mode in which the transmitting fax device looks for acknowledgements during a fax transmission.

### **KSV-21**

The KSV-21 Enhanced Crypto Card contains the cryptographic engine for the STE. The KSV-21 does not support synchronous modes with the STE connected to the PSTN.

### **KOV-14**

The KOV-14 Fortezza Plus Crypto Card is out of production, replaced by the KSV-21 and will no longer function after 31 DEC 2009. When installed in a STE, the KOV-14 allowed the STE to communicate with the installed base of STU-III's.

### **LED**

An acronym for Light Emitting Diode, this is the type of indicator lights used on the 90si.

### **Mil-Std-188-161**

The SECDEF-mandated military standard protocol for digital data transmission between fax devices. Mil-Std-188-161 is compatible with NATO's STANAG 5000 protocols.

### **Off-Hook**

The state created on a telephone line when a telephone handset is picked up.

### **One-Line Dual-Mode Configuration**

This configuration allows the attached fax to function as BOTH a secure fax AND a non-secure fax. An operator must be present to receive an unclassified fax.

### **One-Touch Key**

A feature on a fax machine that allows designated buttons to be programmed to go "Off-Hook" and automatically dial a telephone number. In the case of the 90si, we recommend that you program one of your fax's one-touch

keys to dial a "1" and designate it the "Secure Start" key.

### **Primary Secure Fax**

For the purposes of this document, a Primary Secure Fax is any secure fax system employing the 90si Secure Fax Gateway

### **Primary Non-Secure Fax**

For the purposes of this document, a Primary Non-Secure Fax is a COTS fax connected to a 90si based system that can automatically answer incoming non-secure fax call, just like all the other unclassified faxes you are familiar with.

### **Protocol**

Generally, a protocol is a set of standard rules used to send data over a communications channel. Specifically, secure faxes employ a number of protocols including Mil-Std-188-161 / STANAG 5000, SCIP Async and some older secure fax protocols referred to Modified Group 3.

### **PSTN**

An acronym for Public Switched Telephone Network, it refers to the commercial telephone systems that carry the vast majority of non-mobile telephone calls worldwide.

### **Public Fax**

A document that does not contain sensitive or secret information and, therefore, need not be transmitted in a secure manner.

### **Red Data Port**

The term Red Data Port refers to the RS-232 serial interface on the crypto device to which the 90si's "STE" cable connects. It is also referred to simply as Data Port.

### **RS-232**

Recommended Standard 232 is an industry standard for the electrical interface between communications equipment (such as the STE) and communications terminals (such as the 90si).

### **SCCP**

An acronym for Skinny Call Control Protocol which specifies how an IP telephone instrument connects to and operates with a Cisco Systems

VoIP call router.

### **SCIP**

Secure Communications Interoperability Protocol (SCIP) is a new US, Allied and NATO cryptographic architecture that is employed in new Secure Telephones such as the STE/ECC.

### **SCIP Asynchronous Protocol**

Commonly called the Async protocol, this relatively unused secure fax protocol has become the de facto standard due to the switch from KOV-14 crypto cards to the new KSV-21.

### **SDD (Secure Data Device)**

An SDD is a data only version of secure telephone.

### **Secondary Non-Secure Fax**

For the purposes of this document, a Secondary Non-Secure Fax is a COTS fax connected to a 90si based system that requires manual intervention (an operator) to receive a non-secure fax.

### **Secure Data Mode**

A STU-III or STE's secure data mode encrypts confidential or classified information to be transmitted and received over standard telephone lines. It is this mode that secure faxes are transmitted using.

### **Secure Fax**

A secure fax is a document that contains confidential or classified information that must be transmitted in a secure manner. This term is alternately used to describe the equipment used to transmit and receive classified documents. See Secure Fax Device below.

### **Secure Fax Device**

A specially manufactured fax device that includes the interface and protocols necessary to communicate over secure telephones such as the STU-III.

### **Secure Only Configuration**

This simplest of the 90si configurations allows the attached fax to function as a secure fax and only as a secure fax.

### **SIP**

SIP is an acronym for Session Initiated Proto-

col and refers to a widely used commercial protocol for multimedia sessions over IP networks.

**STE (Secure Terminal Equipment)**

New secure telephone for use by the US Government.

**STU-IIB**

Secure Telephone Unit Generation Two Version B. NATO version of STU-III.

**STU-III**

Secure Telephone Unit Generation Three. No longer in production and set to become obsolete at the end of 2009, the STU-III was the US Government's primary secure communications device for over twenty years.

**STU-IIIA**

Secure Telephone Unit Generation Three Version A. US Secure telephone that can connect with a STU-IIB.

**Synchronous**

Synchronous refers to the way in which data is passed between the 90si and the attached Secure Telephone. Specifically, in synchronous communications each data bit is "clocked" between the 90si and the Secure Phone using clock signals generated by the Secure Phone. The clock signal tells the 90si what "data rate" the Secure Phone is using.

**Two-Line Dual-Mode Configuration**

This 90si configuration allows the attached fax to function as BOTH a secure fax AND a non-secure fax. Unclassified faxes can be received automatically (unattended).

**VoIP**

An acronym for Voice Over Internet Protocol which refers to systems for delivering voice communications over IP networks.

**Volatile Memory**

Employed in the 90si, this type of memory loses its data when power is removed.